

Tizen Avengers - WebApi Guidelines

- I. **Revision History**
- II. **Overview**
- III. **Guideline**
 - 1. **Languages**
 - 2. **Coding style**
 - 3. **API guide**
 - 4. **Unit test criteria**
 - 5. **Source code**
 - 6. **License and Boilerplate**
- IV. **Plugin Structure**
 - 1. **Conventions**
 - 2. **Structure**
 - 3. **Spec file**
 - 4. **Manifest file**
 - 5. **GYP file**
 - 6. **Implementation files**
 - 7. **Plugin flow**
- V. **WIDL**
 - 1. **Conventions**
 - 2. **Architecture**
 - 3. **Example**
- VI. **Tools**
 - 1. **Generate stub code**
 - 2. **Using multiple JavaScript files**
- VII. **Implementation - JavaScript**
 - 1. **Interface creation**
 - 2. **Creating Manager entity**
 - 3. **Properties definition**
 - 4. **Methods definition**
 - 5. **Exporting interface**
 - 6. **Utils**
 - 7. **Exceptions**
 - 8. **Synchronous methods**
 - 9. **Asynchronous methods**
 - 10. **Listeners**
- VIII. **Implementation - C++**
 - 1. **Lifecycle and plugin state**
 - 2. **Privileges**
 - 3. **Namespace and entry points**
 - 4. **Plugin structure**
 - 5. **Asynchronous calls**
 - 6. **Listeners**
 - 7. **Logger**
 - 8. **Error handling**
- IX. **Devel package**
 - 1. **Package structure**
 - 2. **Creating custom web device plugins module**

Revision History

Version	Date	Description	Editor
0.1.0	2015-05-15	Initial Draft	Wojciech Kosowicz w.kosowicz@samsung.com
0.2.0	2015-05-22	Extended version	Pawel Kaczmarek p.kaczmarek3@samsung.com

Version	Date	Description	Editor
0.2.1	2015-06-01	Proofreading	Rafal Galka r.galka@samsung.com
0.3.0	2015-06-08	Supplemented C++ implementation guide	Rafal Galka r.galka@samsung.com
0.4.0	2015-06-16	Guideline	Pawel Kaczmarek p.kaczmarek3@samsung.com
0.5.0	2015-06-18	Devel package	Pawel Kaczmarek p.kaczmarek3@samsung.com
0.5.1	2015-06-24	Add info about WAPIOven.py	Pawel Kaczmarek p.kaczmarek3@samsung.com
0.6.0	2016-10-28	update devel package for tizen 3.0	Annie Park hj.na.park@samsung.com

Overview

This document should be used as a guideline for developers who are creating web plugins for Tizen platform. Conventions and practices described here could be used to develop new web plugins for Tizen 2.4 platform and higher version. Each plugin should be written with great attention on JavaScript.

Guideline

Languages

C++, JavaScript

Coding style

Use Google style guide, C++: <http://google-styleguide.googlecode.com/svn/trunk/cppguide.html>

JavaScript: <http://google-styleguide.googlecode.com/svn/trunk/javascriptguide.xml>

API guide

Tizen Web Device API Guide Lines.pptx

<http://platform.sec.samsung.net/slp/Tizen/Tizen%20Managed%20API/Web%20Device%20API/Tizen%20Web%20Device%20API%20Guide%20Lines.pptx>

Unit test criteria

Tizen-Compliance-Tests-Device-API-UnitTest-Criteria.v0.11_SRPOL.xlsx

http://platform.sec.samsung.net/slp/Tizen/Tizen%20Managed%20API/Web%20Device%20API/Tizen-Compliance-Tests-Device-API-UnitTest-Criteria.v0.11_SRPOL.xlsx

Source code

For Tizen 2.4:

```
$ git clone ssh://<user.id>@168.219.209.56:29418/framework/web/webapi-plugins
$ cd webapi-plugins
$ git checkout origin/tizen_2.4
```

For Tizen 3.0

```
$ git clone ssh://<user.id>@168.219.209.56:29418/framework/web/webapi-plugins
$ cd webapi-plugins
$ git checkout origin/tizen_3.0
```

License and Boilerplate

Use this boilerplate in every new created source files.

```
/*
 * Copyright (c) 2015 Samsung Electronics Co., Ltd All Rights Reserved
 *
 * Licensed under the Apache License, Version 2.0 (the "License");
 * you may not use this file except in compliance with the License.
```

```

* You may obtain a copy of the License at
*
* http://www.apache.org/licenses/LICENSE-2.0
*
* Unless required by applicable law or agreed to in writing, software
* distributed under the License is distributed on an "AS IS" BASIS,
* WITHOUT WARRANTIES OR CONDITIONS OF ANY KIND, either express or implied.
* See the License for the specific language governing permissions and
* limitations under the License.
*/

```

Plugin Structure

Conventions

Each plugin is kept in separate directory inside `src/` folder written in lowercase convention.

Structure

Each plugin contains following structure:

- `<pluginname>.gyp`
- `<pluginname>_api.js`
- `<pluginname>_extension.h`
- `<pluginname>_extension.cc`
- `<pluginname>_instance.h`
- `<pluginname>_instance.cc`

Spec file

Spec file (`webapi-plugins.spec`) kept inside `packaging/` directory is build specification file used by RPM packaging system where variables are defined. Those variables can be used to include or exclude particular modules from build for each profile (mobile, TV, wearable).

Manifest file

Each RPM package must have a manifest file where developers can specify the access control domain in which their application should be running and potentially additional security policies for the application. It is necessary to build the project. The manifest file (`webapi-plugins.manifest`) is located in the root directory of the project.

GYP file

Each plugin has its own gyp file that contains information specific for it. Plugin configuration file (gyp) is the equivalent of CMake. It contains information what files to build what libraries to use for linking. There can be also found one main gyp file in `src/` folder (`tizen-wrt.gyp`) that includes others.

Implementation files

Description of files required in plugin implementation.

- **C++ files** (`<pluginname>_extension.h`, `<pluginname>_extension.cc`)
Extension namespace and other objects exported by JavaScript layer are set inside these files.
- **C++ files** (`<pluginname>_instance.h`, `<pluginname>_instance.cc`)
These files are responsible for communication between JavaScript layer and Native API.
- **JavaScript file** (`<pluginname>_api.js`)
This file contains all methods required by each API. All operation should be done by JavaScript as much as possible. If JavaScript can do something, it should do it. This file is responsible for checking arguments, calling C++ methods etc.

Plugin flow

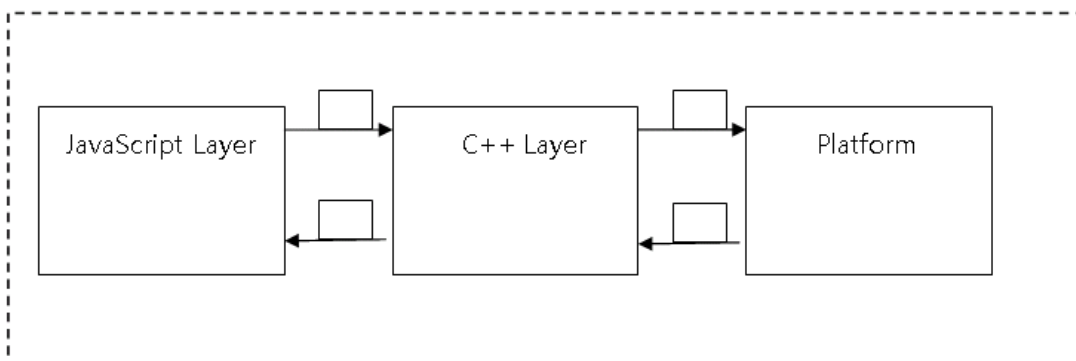

Explanation of steps:

1. From JavaScript Layer information is sent to C++ Layer. This information consists of type of call (asynchronous, synchronous) arguments given by user, any additional information that is required to successfully acquire required data. Data is sent in form of JSON.
2. C++ parses acquired JSON. After the data is processed. Appropriate platform functions are called with the specified arguments.
3. Platform returns specified values to C++ layer.
4. Another JSON is formed. It consists of data that was acquired from platform.

WIDL

Conventions

Currently WIDL version that is used in Samsung is described here: <http://www.w3.org/TR/WebIDL/>. This is document from 19 April 2012.

WIDL used for plugins creation is closer to previous drafts mainly this from 21 October 2010. It is described here: <http://www.w3.org/TR/2010/WD-WebIDL-20101021/>.

Architecture

Each plugin is separated from each other as a different module. We do this by using module key name.

```
1. module identifier {
2.   definitions
3. }
```

Each module describes space, binding many connected definitions in one namespace. Inside each module there are sets of **interface** defined. Most of the time there is one major interface defined, which is **NoInterfaceObject**. This is manager object which has only one property which is object that actually implements manager functionality.

```
1. interface identifier : identifier-of-inherited-interface {
2.   interface-member...
3. };
```

Interface is a definition of an object, which can be realized in a system (an inheritance and overloading is possible). In interface definition you can put following members:

- Constants.
- Attribute : Interface member, which represents variable inside object, can be changed, if it is not read only.
- Operation: Interface member, which represents method inside object. It is a function of programming language, which can be executed and returns a result.
- Special operation: Performs a specific task. i.e. deleter, getter
- Static operation: It is not called for a specific instance of the interface, is called for static object regardless of an instance creation. It is connected with the interface itself.

```
1. interface identifier {
2.   attribute type identifier;
3.   [extended-attribute] const type identifier = value;
4.   [extended-attribute] attribute type identifier;
5.   readonly attribute type identifier;
6.   attribute type identifier inherits getter; ///Declared to change read only attribute //inherited from interface
7.   attribute type identifier getraises (NoSuchValue); ///Exception declaration
8.   return-type identifier(arguments...);
9.   return-type identifier(argument-type argument-identifier); ///regular operation
10.  return-type identifier(optional argument);
11.  special-keywords return-type identifier(arguments); ///special operation
12.  [extended-attribute]return-type identifier(arguments...); ///A variable number of //arguments
13.  return-type identifier(arguments) raises (identifier) ///raises exception
14.  caller return-type identifier(argument);
15.  caller return-type (argument);
16.  static return-type identifier(arguments);
17. };
```

Next step is to connect manager implementation with Tizen object.

```
1. Tizen implements ManagerObject
```

To provide actual implementations of ManagerObject, instance of its Manager interface definition has to be made. Inside this Manager interface all attributes and functions that will be available from manager namespace, should be defined. There can be attributes which are other interfaces, operations and everything that interfaces allows.

Additional interface can be available as a standalone types not connected to global namespace. Those are either obtained from operation of other interfaces or constructed with their constructor method. Interface which are constructible are described as follows:

```
1. [Constructor(type arg1, optional type? Arg2)]
2. Interface ConstructibleInterface {
3.   attributes
4.   operations
5.   an so on...
6. };
```

As one can see list of parameters is specified for such constructor. Not all parameters are mandatory, some can be preceded by `optional` keyword and `?` mark, after type to mark that this is not obligatory argument. Additionally some operations can be followed by `raises` key word to mark that, described exception type can be thrown during execution of such method.

Because some operations can be asynchronous, it is necessary to provide callbacks objects that can be executed by such operation. Callback object is special type of `interface` object with `Callback=FunctionOnly` extended attribute.

```
1. [Callback=FunctionOnly, NoInterfaceObject] interface SomeCallback {
2.   void someMethod(type agr1, ...)
3. };
```

On the purpose of listeners which accepts dictionaries, there are callbacks that support more than one method. There is another definition of callback which lacks of keyword `FunctionOnly`.

```
1. [Callback, NoInterfaceObject] interface SomeDictionaryCallback {
2.   void firstmethod(type somearg1, ... );
3.   void secondmethod(type somearg2, ... );
4.   any additional methods...
5. };
```

Example

Example of WIDL file:

```
1. module Sample {
2.
3.   enum SampleEnums {
4.     "ENUM1",
5.     "ENUM2",
6.     "ENUM3",
7.   };
8.
9.   typedef (SampleEnums) SampleType;
10.
11.  [NoInterfaceObject] interface SampleManagerObject {
12.    readonly attribute SampleManager sample;
13.  };
14.
15.  Tizen implements SampleManagerObject;
16.
17.  [NoInterfaceObject] interface SampleManager {
18.    void sampleMethod(SampleType param1, Sample2 param2) raises(WebAPIException);
19.    double sampleMethod2(SampleType param1) raises(WebAPIException);
20.    void sampleMethod3(SampleCallback callback) raises(WebAPIException);
21.  };
22.
23.  [Callback=FunctionOnly, NoInterfaceObject]
24.  interface SampleCallback {
25.    void onsuccess(Sample1 param1, Sample2 param2);
26.  };
27. };
```

Tools

Generate stub code

To generate stub files from the widl you can use stub generator located in `tools/skeleton_generator/` directory and run the python command:

```
$ python WAPIOven.py -d <stub code destination directory name> <widl directory/pluginname>.widl
```

If tizen.widl is needed, add tizen.widl

```
1. $ python WAPIOven.py -d <stub code destination directory name> <widl directory/pluginname>.widl <widl directory/>tizen.widl
```

Path to WAPIOven.py:

```
$ tools/skeleton_generator/WAPIOven.py
```

You need to install jinja2 for WAPIOven.py:

```
$ sudo apt-get install python-jinja2
```

Example:

```
$ sudo apt-get install python-jinja2
$ cd tools/skeleton_generator/
$ python WAPIOven.py -d ../../src/notification/ /web-device-api/web/widl/tizen/notification.widl
```

WIDL files can be found in the project repository:

```
$ git clone ssh://<username>@168.219.209.56:29418/doc/web-device-api
```

The widl files are placed in: [web-device-api/web/widl/tizen/](#)

Stub files generated by above command:

```
<pluginname>_api.js
<pluginname>_extension.h
<pluginname>_extension.cc
<pluginname>_instance.h
<pluginname>_instance.cc
```

What should be done when skeleton code was generated?

- `<pluginname>.gyp` file should be added
- entry points should be checked in `<pluginname>_extension.cc` file
- each method should be implemented in `<pluginname>_instance.cc` file

Using multiple JavaScript files

To use multiple JavaScript files in one plugin create `js/` directory inside plugin directory and place JavaScript files.

Inside `<pluginname>_api.js` required JavaScript files should be added:

```
//= require('common.js');
//= require('calendar_item.js');
//= require('calendar.js');
//= require('calendar_manager.js');
//= require('calendar_attendee.js');
//= require('calendar_alarm.js');
//= require('calendar_recurrence_rule.js');
```

To merge all JavaScript files `tools/mergejs.py` file is used. This script merge all files mentioned in `<pluginname>_api.js` file into one file before build process.

Implementation - JavaScript

Each plugin contains JavaScript files. This is the place where user input is being processed validated before send to C++ layer.

Badge API will be used to show the creation of JavaScript file (lot of content of this file will be already generated via Stub Generator).

Interface creation

The WIDL of BadgeManager – main entity that holds all the API methods looks like following:

```
1. [NoInterfaceObject] interface BadgeManager {
2.     readonly attribute long maxBadgeCount
3.     void setBadgeCount(ApplicationId appId, long count) raises(WebAPIException);
4.     long getBadgeCount(ApplicationId appId) raises(WebAPIException);
5.     void addChangeListener(ApplicationId[] appIdList, BadgeChangeCallback successCallback) raises(WebAPIException);
6.     void removeChangeListener(ApplicationId[] appIdList) raises(WebAPIException);
7. };
```

Creating Manager entity

Object that will hold attributes and methods is defined as JavaScript function:

```
1. function BadgeManager() {}
```

Properties definition

Properties are defined within the created JavaScript function like this:

```
1. var MAX_BADGE_COUNT = 999;
2. Object.defineProperties(this, {
3.   maxBadgeCount: {value: MAX_BADGE_COUNT, enumerable: true, writable: false}
4. });
```

Because the property was defined as `const`, `writable` is set to `false`.

Methods definition

In accordance to WIDL `BadgeManager` contains `setBadgeCount` method. To define this method within JavaScript use prototype extension functionality:

```
1. BadgeManager.prototype.setBadgeCount = function() {};
```

Exporting interface

Once the object is created and all the methods and attributes are set it has to be exported so it will be visible when making call to `tizen.badge` namespace. This is done using assigning new object instance to exports variable:

```
1. exports = new BadgeManager(); //exported as tizen.badge
2. exports = new CalendarManager(); //exported as tizen.calendar
```

Other namespaces within the module are exported as below:

```
1. tizen.CalendarAttendee = CalendarAttendee;
2. tizen.CalendarEvent = CalendarEvent;
3. tizen.CalendarTask = CalendarTask;
```

Utils

In `src/Utils/Utils_api.js` file there is a lot of useful tools that allow automatization of certain operations. Most often used tools from `Utils_api.js` are `converter` and `validator`. All tools are available under `xwalk.Utils` namespace.

Converter

A lot of times conversion between JavaScript types will be required. The `converter` tool was created in order to make this operation easier.

```
1. var converter_ = xwalk.Utils.converter;
2. var number = converter_.toLong(result);
```

Validator

When API JavaScript method is called first thing that has to be done in JavaScript layer of api implementation is to process and validate arguments given by the user. The process of validation consists of ensuring that the proper amount of arguments was given and that they were of the expected type and throwing exception if necessary.

Validator helps to ensure that user sent proper values. Validator is available at `xwalk.Utils.validator` and predefined js types at `xwalk.Utils.validator.types`

Below can be found example of using validator inside `setBadgeCount` method that requires `appId` in form of string and long count value:

```
1. var validator_ = xwalk.Utils.validator;
2. var types_ = validator_.Types;
3.
4. var args = validator_.validateArgs(arguments, [
5.   {name: 'appId', type: types_.STRING},
6.   {name: 'count', type: types_.LONG}
7. ]);
```

Exceptions

At some point whether improper data is received or given to JavaScript might require to throw exceptions. The example below shows how to throw properly predefined exceptions:

```
1. throw new WebAPIException(WebAPIException.TYPE_MISMATCH_ERR,  
2.     'Incorrect number of arguments');
```

WebAPIException constructor takes as argument the type of error to be thrown. The second additional argument is error message.

Synchronous methods

In order to perform synchronous operation (one that does not require callback and the result is given instantly) callSync() method of Native manager needs to be called:

```
1. var native_ = new xwalk.utils.NativeManager(extension);  
2. var ret = native_.callSync('BadgeManager_setBadgeCount', {  
3.     appId: args.appId,  
4.     count: args.count  
5. });  
6. if (native_.isFailure(ret)) {  
7.     throw native_.getErrorObject(ret);  
8. }
```

The first argument is the command name registered in C++ layer that has to be called, the second is arguments object that will be passed to this method. Result is assigned to ret variable.

Asynchronous methods

In order to work with method that requires callback instead of callSync(), call() method needs to be called. Apart from the first two arguments that are exactly the same as in call() method (c++ method binding, object) it takes additional argument that is a function that will be called when the native call is processed:

```
1. var native_ = new xwalk.utils.NativeManager(extension);  
2. var callback = function(result) {  
3.     if (native_.isFailure(result)) {  
4.         native_.callIfPossible(args.errorCallback, native_.getErrorObject(result));  
5.     } else {  
6.         var calendars = native_.getResultObject(result);  
7.         var c = [];  
8.         calendars.forEach(function(i) {  
9.             c.push(new Calendar(new InternalCalendar(i)));  
10.        });  
11.        args.successCallback(c);  
12.    }  
13. };  
14.  
15. native_.call('CalendarManager_getCalendars', callArgs, callback);
```

Listeners

In order to work with listeners NativeManager provides addListener and removeListener methods. This method takes two arguments: one is unique listenerId that will be processed when making a call from C++ to JavaScript. The second one is the function that is called whenever expected event occurs.

```
1. var native_ = new xwalk.utils.NativeManager(extension);  
2. var listenerId = 'PLUGIN_LISTENER_NAME';  
3. native_.addListener(listenerId, function(data) {  
4.     // handle event data  
5. });  
6. native_.callSync('Calendar_addChangeListener', {  
7.     type: this.type,  
8.     listenerId: listenerId  
9. });
```

Implementation - C++

Lifecycle and plugin state

All plugins instances are created by runtime on application launch. It's important to not initialize any database/service connections and platform handlers in instance constructor. All resources should be "lazy" initialized just before first use, to keep starting time as short as possible. At the beginning the initializer loads only basic information from plugins.json. This file is being generated during plugins build process, its body depends on defined modules. Initialized resources can be referenced to instance and kept for further usage. Instance destructor is called on application termination and should release all used resources to prevent memory leaks.

Native layer should be considered as stateless. It means that there is no strict reference between JavaScript and native data.

Example: If operation should change some object retrieved from platform, identifier should be passed again and additional check if object still exists should be made.

Privileges

Some of the API methods require privilege access. The privilege engine used in the project is Cynara. In Tizen 3.0 checking if application has privilege to call method has been moved to C++ layer. It's the first step which should be checked.

Below can be found example of using Privilege in Alarm API:

```
1. const std::string kPrivilegeAlarm = "http://tizen.org/privilege/alarm.get";
2.
3. // inside add, remove, removeAll methods:
4. CHECK_PRIVILEGE_ACCESS(kPrivilegeAlarm, &out);
```

Namespace and entry points

Extension namespace and other objects exported by JavaScript layer are defined inside `<pluginname>_extension.cc` file.

```
1. SetExtensionName("tizen.notification"); //exported in JS as new NotificationManager();
2. const char* entry_points[] = {"tizen.StatusNotification",
3.                               "tizen.NotificationDetailInfo",
4.                               NULL};
```

Plugin structure

In general `Instance` class (`<pluginname>_instance.cc`) should be treated as command dispatcher and should be as small as possible (similar to Controller in MVC). It's responsibility should be limited to reading/validating arguments, forwarding call to business logic component and passing result to JavaScript layer. Business logic should be implemented in additional classes with SOLID principles in mind.

Commands callable from JavaScript layer should be registered in constructor of `<PluginName>Instance` class which extends `common::ParsedInstance`.

```
1. // <pluginname>_instance.h
2. class MediaControllerInstance : public common::ParsedInstance {}
```

Currently there is no difference in registering sync and async commands. But good practice is to separate them for readability and maintainability. Common practice is to define two macros and call `RegisterSyncHandler` method from `common::ParsedInstance`.

```
1. // <pluginname>_instance.cc
2. MediaControllerInstance::MediaControllerInstance() {
3.     #define REGISTER_SYNC(c, x) \
4.         RegisterSyncHandler(c, std::bind(&MediaControllerInstance::x, this, _1, _2));
5.     #define REGISTER_ASYNC(c, x) \
6.         RegisterSyncHandler(c, std::bind(&MediaControllerInstance::x, this, _1, _2));
7.
8.     REGISTER_SYNC("MediaControllerManager_getClient",
9.                 MediaControllerManagerGetClient);
10.    REGISTER_ASYNC("MediaControllerClient_findServers",
11.                 MediaControllerClientFindServers);
12.
13.    // ... other commands
14.
15.    #undef REGISTER_SYNC
16.    #undef REGISTER_ASYNC
17. }
```

Static method registered as a handler must have proper signature:

```
1. void InstanceClass::HandlerName(const picojson::value& args, picojson::object& out);
```

- `args` - object containing arguments passed from JavaScript layer
- `out` - object containing response data returned synchronously to JavaScript layer.

`ReportSuccess()`, `ReportError()` or `LogAndReportError()` helpers should be used to ensure proper structure of `out` object. `LogAndReportError()` expands `ReportError()` function. It sets error in `out` object but additionally prints message if `ERROR` log priority is on.

```
1. picojson::value data = picojson::value<picojson::object>;
2. const PlatformResult& result = model_->DoSomethingWithData(&data);
3. if (!result) {
4.     LogAndReportError(result, &out);
5.     return;
6. }
7.
8. ReportSuccess(data, out);
```

Asynchronous calls

To perform asynchronous request `common::TaskQueue` component should be used. You should use lambda expression which calls business logic and passes result to JavaScript layer by calling `PostMessage(const char* msg)`.

Asynchronous response is not matched to request automatically. You should pass `callbackId` received from JavaScript layer as an argument. It allows to call the appropriate user callback in JS async message handler.

```
1. auto search = [this, args]() -> void {
2.
3.     // business logic
4.     picojson::value servers = picojson::value(picojson::array());
5.     PlatformResult result = client_->FindServers(&servers.get<picojson::array>());
6.
7.     // response object
8.     picojson::value response = picojson::value(picojson::object());
9.     picojson::object& response_obj = response.get<picojson::object>();
10.    response_obj["callbackId"] = args.get("callbackId");
11.    if (result) {
12.        ReportSuccess(servers, response_obj);
13.    } else {
14.        LogAndReportError(result, &response_obj);
15.    }
16.
17.    // post JSON string to JS layer
18.    PostMessage(response.serialize().c_str());
19. };
20.
21. TaskQueue::GetInstance().Async(search);
```

Listeners

Sending events from platform listeners is very similar to sending asynchronous responses. `PostMessage(const char* msg)` should be called with `listenerId` passed from JavaScript layer.

```
1. auto listener = [this, args](picojson::value* data) -> void {
2.
3.     if (!data) {
4.         LoggerW("No data passed to json callback");
5.         return;
6.     }
7.
8.     picojson::object& request_o = data->get<picojson::object>();
9.     request_o["listenerId"] = args.get("listenerId");
10.
11.     PostMessage(data->serialize().c_str());
12. };
```

Logger

Logger is available from `common/logger.h`. Available log priorities are: `DEBUG`, `INFO`, `WARN` and `ERROR`. Each priority has macro which should be used to filter messages based on level of importance:

- `LoggerD()` prints message with `DEBUG` priority
- `LoggerI()` prints message with `INFO` priority
- `LoggerW()` prints message with `WARNING` priority
- `LoggerE()` prints message with `ERROR` priority

Example:

```
1. LoggerD("Entered to getAll() function");
```

```
2. LoggerI("Data size: %d", object->data->size);
3. LoggerW("Data in %s object is empty", object->name);
4. LoggerE("Error occurred while getting data [%d]", error);
```

Error handling

Regarding to [Google C++ Style Guide](#) we do not use Exceptions.

To deliver error conditions to JavaScript layer, that can occur in the platform, `LogAndReportError` or `ReportError` method should be used. All available error codes are defined in `common/platform_result.h`

`LogAndReportError` can be used anywhere in native layer. It sets `PlatformResult` error object in response object which should be converted to exception and thrown in JavaScript layer:

```
1. // C++ layer
2. LogAndReportError(PlatformResult(ErrorCode::NOT_FOUND_ERR, "Cannot remove notification error"), &out);
3. LogAndReportError(PlatformResult(ErrorCode::UNKNOWN_ERR, "Cannot get notification id error"), &out);
```

```
1. // JavaScript layer
2. var native_ = new xwalk.utils.NativeManager(extension);
3. if (native_.isFailure(ret)) {
4.     throw native_.getErrorObject(ret);
5. }
```

Devel package

After build process `webapi-plugins-devel-xxx.rpm` should be generated in `gbs` directory. Package contains required common headers files, `gypi` files and `webapi-plugins.pc` file.

Package structure

```
| -usr
| ---include
| ----webapi-plugins
| -----src
| -----common
| -----tools
| -----gyp
| -----pylib
| -----gyp
| -----generator
| -----slimit
| -----ply
| -----tests
| -----visitors
| ---lib
| ----pkgconfig
```

File `webapi-plugins.pc` source:

```
1. project_name=webapi-plugins
2. dirname=tizen-extensions-crosswalk
3. prefix=/usr
4. exec_prefix=${prefix}
5. libdir=${prefix}/lib/${dirname}
6. includedir=${prefix}/include/${project_name}/src
7.
8. Name: ${project_name}
9. Description: ${project_name}
10. Version:
11. Requires: dbus-1 dlog glib-2.0
12. Libs: -L${libdir} -ltizen_common
13. Cflags: -I${includedir}
```

Creating custom web device plugins module

To create custom web device plugins module `webapi-plugins.spec`, `tizen-wrt.gyp`, `webapi-plugins.manifest` and `src` files are needed. Skeleton below shows the required structure of test module.

```
| — packaging
|   — webapi-plugins.spec
```

```

└─ src
  └─ test
    └─ test_api.js
    └─ test_extension.cc
    └─ test_extension.h
    └─ test.gyp
    └─ test_instance.cc
    └─ test_instance.h
  └─ tool
    └─ desc_gentool.cc
    └─ tool.gyp
└─ tizen-wrt.gyp
└─ webapi-plugins.manifest

```

webapi-plugins.spec source:

```

1. %bcond_with wayland
2.
3. %define _manifestdir %{TZ_SYS_RW_PACKAGES}
4. %define _desktop_icondir %{TZ_SYS_SHARE}/icons/default/small
5.
6. %define crosswalk_extensions tizen-extensions-crosswalk
7.
8. %define crosswalk_extensions_path %{_libdir}/%{crosswalk_extensions}
9.
10. Name:      webapi-plugins-test
11. Version:   0.1
12. Release:   0
13. License:   Apache-2.0 and BSD-2.0 and MIT
14. Group:     Development/Libraries
15. Summary:   Tizen Test Web APIs
16. Source0:   %{name}-%{version}.tar.gz
17.
18. %ifarch %{arm} aarch64
19. # ARM
20. %define tizen_is_emulator      0
21. %else
22. # I586
23. %define tizen_is_emulator      1
24. %endif
25.
26. BuildRequires:  ninja
27. BuildRequires:  pkgconfig(webapi-plugins)
28.
29. %description
30. Tizen Test Web APIs
31.
32. %prep
33. %setup -q
34.
35. %build
36.
37. export GYP_GENERATORS='ninja'
38. GYP_OPTIONS="--depth=. -Dtizen=1 -Dextension_build_type=Debug -Dextension_host_os=%{profile} -Dprivilege_engine=%{tizen_privilege_engine}"
39. GYP_OPTIONS="$GYP_OPTIONS -Ddisplay_type=%{display_type}"
40. GYP_OPTIONS="$GYP_OPTIONS -Dcrosswalk_extensions_path=%{crosswalk_extensions_path}"
41.
42. # feature flags
43. GYP_OPTIONS="$GYP_OPTIONS -Dtizen_is_emulator=%{?tizen_is_emulator}"
44.
45. /usr/include/webapi-plugins/tools/gyp/gyp $GYP_OPTIONS src/tizen-wrt.gyp
46.
47. ninja -C out/Default %{?_smp_mflags}
48.
49. %install
50.
51. # Extensions.
52. mkdir -p %{buildroot}%{crosswalk_extensions_path}
53. install -p -m 644 out/Default/libwebapis*.so %{buildroot}%{crosswalk_extensions_path}
54.
55. # execute desc_gentool
56. LD_LIBRARY_PATH=$LD_LIBRARY_PATH:%{buildroot}%{crosswalk_extensions_path} out/Default/desc_gentool \
57.   %{crosswalk_extensions_path} \
58.   %{buildroot}%{crosswalk_extensions_path} > webapis-plugins.json
59.
60. # temporary plugins description for lazy loading
61. install -p -m 644 webapis-plugins.json %{buildroot}%{crosswalk_extensions_path}/webapis-plugins.json

```

```
62.
63.
64. %files
65. %{crosswalk_extensions_path}/libwebapis*.so
66. %{crosswalk_extensions_path}/webapis-plugins.json
67. %manifest webapi-plugins.manifest
```

tizen-wrt.gyp source:

```
1. {
2.   'includes':[
3.     '/usr/include/webapi-plugins/src/common/common.gypi',
4.   ],
5.
6.   'targets': [
7.     {
8.       'target_name': 'extensions',
9.       'type': 'none',
10.      'dependencies': [
11.        'tool/tool.gyp:*',
12.        'test/test.gyp:*',
13.      ],
14.      'conditions': [],
15.    },
16.  ],
17. }
```

test.gyp source:

```
1. {
2.   'includes':[
3.     '/usr/include/webapi-plugins/src/common/common.gypi',
4.   ],
5.   'targets': [
6.     {
7.       'target_name': 'webapis_test',
8.       'type': 'loadable_module',
9.       'sources': [
10.        'test_api.js',
11.        'test_extension.cc',
12.        'test_extension.h',
13.        'test_instance.cc',
14.        'test_instance.h',
15.      ],
16.      'include_dirs': [
17.        '..',
18.        '<(SHARED_INTERMEDIATE_DIR)',
19.      ],
20.      'variables': {
21.        'packages': [
22.          'webapi-plugins',
23.        ],
24.      },
25.    },
26.  ],
27. }
```

[webapi-plugins-devel-test.zip](#) contains test module which depends on webapi-plugins devel package. Custom web device plugins module test is placed in `src/` directory and contains all required files. Please see [Plugin structure](#) chapter for more details.

To install custom web device plugins module `webapi-plugins-xxx.rpm` and `webapi-plugins-devel-xxx.rpm` must be installed first. After build and installation webapi-plugins-test `webapis.test` namespace should be available.

```
1. var test = webapis.test.ping();
2. console.log(test); // Hello!
```